



- **Advanced fully software-defined architecture**
- **Intuitive and user-friendly touch-screen interface**
- **Wireless operation via iOS, Android & Windows devices**
- **Selcall / Telcall**
- **Address books**
- **SMS - Pagecall**
- **Multiple Self ID's**
- **Wi-Fi Adaptor (optional)**
- **4049 Auto tune HF antenna with internal GPS receiver**
- **GPS interface software**

Designed and built in Australia for the world's harshest conditions, Barrett HF equipment thrives in the outback and has the track record to prove it. The Barrett "Outback Traveller Pack" should be considered as standard equipment for anyone travelling in remote areas.

Utilising the "free to air" nature of HF communications, the "Outback Traveller Pack" provides access to essential safety and emergency services with no ongoing call charges.



The Barrett 4050se handset app supports iOS, Android and Windows devices for wireless voice and radio control when using the Wi-Fi adaptor option.





4050 se HF SSB transceiver features

(Features and options listed below are standard inclusions with the 4050se HF SDR Outback Traveller Pack).

HF spectrum coverage

Transceiver will be programmed to meet Australian Communications and Media Authority (ACMA) requirements.

Selective call - Selcall

Selective call - Selcall - provides a simple and efficient method of calling stations within an HF network. The 4050se allows either 4 or 6 digit Selcalls which can be programmed into the transceiver on a channel by channel basis. Selcall ID's and details can be stored in the internal address book.

Direct dial telephone calls

Telcall allows telephone access utilising direct dial telephone services (such as those provided by 4WD HF Radio Networks) to place or receive telephone calls without the requirement to go through an operator (call charges may apply).

Scanning

Channel scanning combined with Selcall enables calls to get through on the channel most suitable. Eight scan tables are available with up to 30 channels programmable per table.

Emergency Selcall with geographical position

The Barrett 4050se displays and annunciates emergency selective calls, also showing the position of the station sending the emergency call if it is fitted with a GPS receiver.

Scan resume - no missed calls

If the transceiver has been left unattended it automatically returns to scanning and is ready to receive calls on any channel.

Call history

Detail of all recent calls, including call type, time, date and Selcall ID are held in history buffers for future viewing.

SMS

Allows short text messages to be sent from one 4050se transceiver to another using the touch screen interface on the control screen.

Tunable receiver

Tunes all frequencies, in all modes, between 500kHz to 30MHz down to 1Hz steps.

Rugged construction

An extruded aluminium chassis combined with a rugged weather resistant polycarbonate alloy front panel has been designed to withstand harsh and hostile environments. Extensive vibration testing and temperature cycling has proved the Barrett 4050se will operate in the world's toughest environments.

Compact, easy to install remote control head for vehicles

The 4050se remote control configuration is ideal for installation into today's compact vehicles.

Noise reduction

The 4050se utilises a Digital Signal Processing (DSP) noise reduction system.

GPS interface software

The GPS interface software installed in your transceiver used in conjunction with the supplied 4049 antenna internal GPS receiver will enable GPS positioning functionality. The 4050se will display your current position (latitude and longitude). You can transmit your position to another Barrett transceiver, and have the ability to interrogate the position of other similarly equipped Barrett transceivers. You can also log your position into the base station database operated by some HF networks.

The "Outback Traveller Pack" includes

Barrett 4050se HF SSB transceiver with remote control head, extension speaker, vehicle mounting cradle, mounting hardware and Barrett 4049 automatic tuning mobile antenna with internal GPS and two section whip.



Barrett 4050se HF SDR remote head configuration

4049 Automatic tuning mobile HF antenna

The Barrett 4049 Automatic Tuning Mobile HF Antenna (P/N BC404901) is specifically designed to interface with Barrett 4000 series HF transceivers.

The Barrett 4049 ATU is fitted with an internal GPS simplifying system installation.

Providing a frequency coverage of 1.5 to 30 MHz, the Barrett 4049 features rapid tuning (typically less than 1.5 s) and low power consumption capabilities.

When paired with a Barrett 4000 series HF Transceiver, the 4049 memory tune feature eliminates the need to retune an antenna after a channel change. When returning to a previously tuned channel, the transceiver sets the 4049 with a stored tuning result in less than 100 ms.

The active tuning elements of the antenna are housed in a waterproof, high-impact resistant moulding. This housing incorporates a heavy duty anti-vibration mount at its base. Even with its rugged construction, the Barrett 4049 weighs only 3.65kg.

The 4049 is supplied as standard with a 6 metre composite RF control cable and a two piece fibreglass MIL-STD whip and spring.

General Specifications

Frequency range	1.5 - 30 MHz (continuous) with whip 3.2 m or longer / Barrett NVIS antenna 2 - 30 MHz (continuous) with Barrett 2 piece whip antenna
Power	150 W PEP (digital, voice and data)
VSWR	Better than 2:1 when tuned
Tuning time	Less than 1.5 seconds (typical) From memory, less than 100ms
Operating temperature	-30°C to +70°C
Humidity	95% relative, non-con-densing
Environmental	IP67
Supply voltage	12-13.8 V DC (derived from transceiver)
Antenna impedance	50 ohm unbalanced
Mounting	M16 stud with provision for padlock
Weight	3.90 kg
Case construction	Moulded Nylon-66 glass-filled with powder-coated stainless-steel base
Colour	Black
Input current	Average 80 mA @ +12.6 V input

- **1.5 - 30 MHz Tuning range**
- **Compact Size**
- **150 W (Digital, voice and Data)**
- **Internal GPS**
- **ALE 2G/3G Compatible**
- **Memory Tune (100 ms)**
- **Mil-STD 810G**

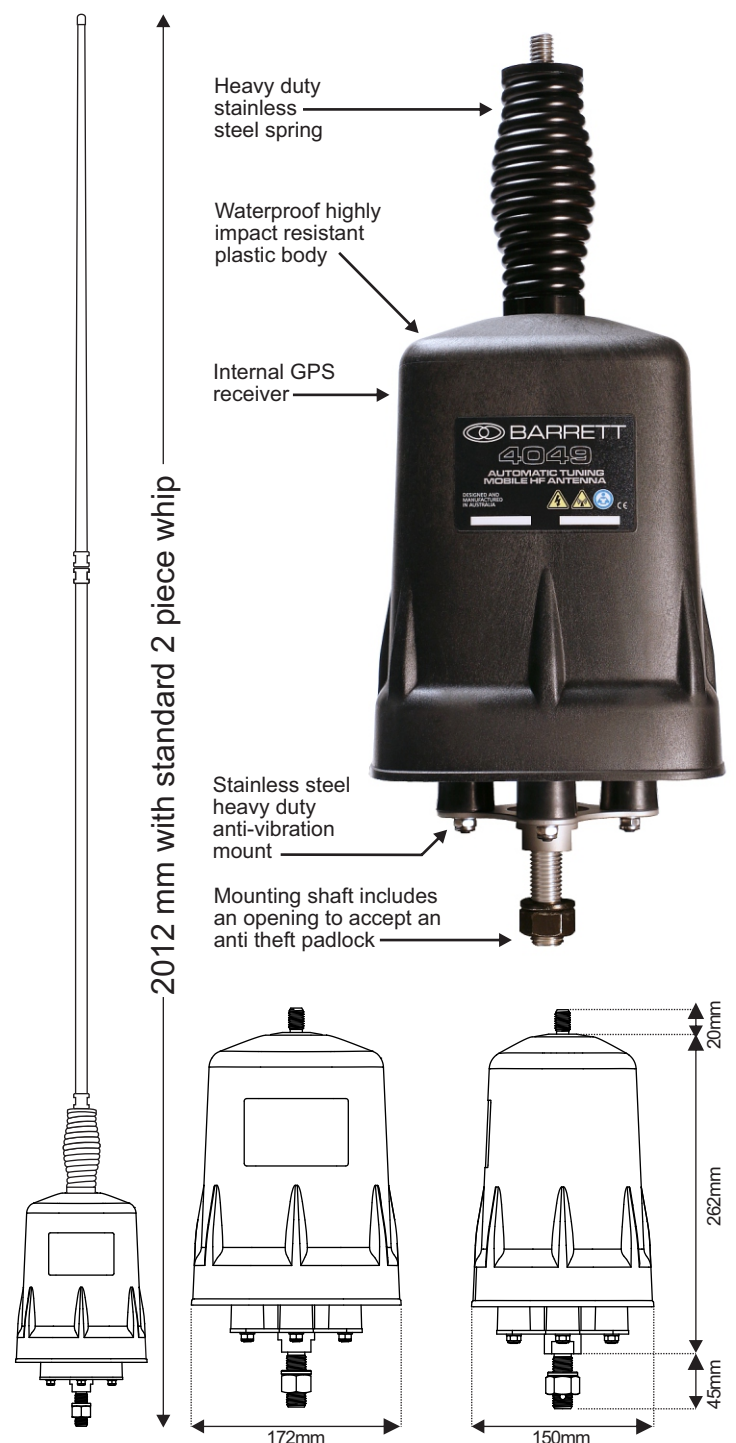

General Specifications

TX Frequency Range	1.5MHz – 30MHz (reduced performance below 1.6MHz)
RX Frequency Range	250KHz – 30MHz
Channel Capacity	200
Address Book	300 contacts
Frequency Stability	± 0.5 PPM -30°C to +70°C (±0.1 PPM available optionally)
Frequency Resolution	10 Hz program mode; 1 Hz tunable receiver
Operating Modes	J3E (USB, LSB) - H3E (AM) - J2A (CW) - CF (Custom Filter) - ISB (data option)
Filter Bandwidths	Fully Software-Defined standard and custom filter range from 300Hz to 3000Hz and beyond.
Operating Temperature	-30° to +70°, relative humidity 95%, non condensing
Supply Voltage System	+11V DC or +28V DC operation Selcall Based on CCIR 493-4, 4 and 6 digit systems
Current Consumption	350mA standby (muted)
Sensitivity	-121dBm (0.20µV) for 10dB SINAD
RF Output Power	100W PEP

Specifications are typical. Equipment descriptions and specifications are subject to change without notice or obligation.

Summary of features and options

- Advanced fully software-defined architecture
- Intuitive and user-friendly touch-screen interface
- Advanced calling features
- Detachable Front Panel
- Enhanced DSP noise reduction
- Selcall/Telcall
- "SMS Pagecall" short text messaging
- 1.5 to 30 MHz continuous
- 3 year warranty (Standard)
- Free Scroll Transmit (Option)
- Wi-Fi Adaptor (Option)
- Control Handset (Option)

Dimensions and Weights

4050se remote control head
(trunk mount configuration)
Weight 0.35 kg

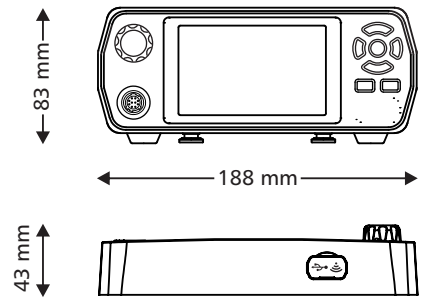

4050se remote control configuration
(trunk mount) main unit
Weight 2.2 kg

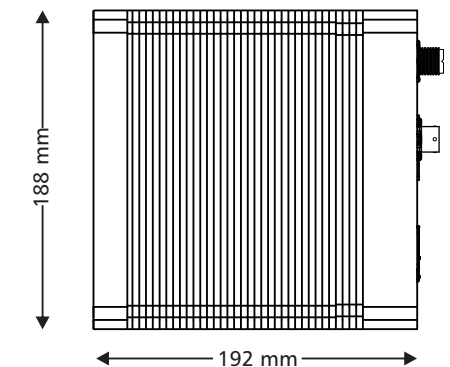

4050se local control configuration
Weight 2.55 kg

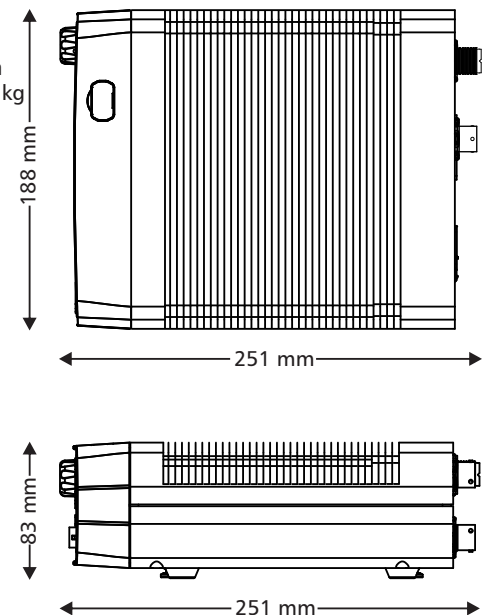

BCB4050D01/4



Head Office:
Barrett Communications Pty Ltd
47 Discovery Drive, Bibra Lake,
WA, 6163 AUSTRALIA
Tel: +61 8 9434 1700
Email: information@barrettcomms.com

www.barrettcomms.com